

## Innovative Solutions



Driven by



- Intuitive, 10.4" LCD touch-screen GUI
- So easy to operate that no instructions are needed!
- Multi-lingual capability allowing use throughout the world.
- Message scheduler for time and event-based messages.
- NTCIP compatibility for simple, hassle-free integration into standard ITS installations.
- USB "thumb drive" interface for hassle-free, quick updates via the SolarTech website as well as data collection (with optional Radar).



**Mega-Flux LED Display:**  
A patented wide-angle lens is fitted to each LED, increasing the viewing angle from 23° to 60°.

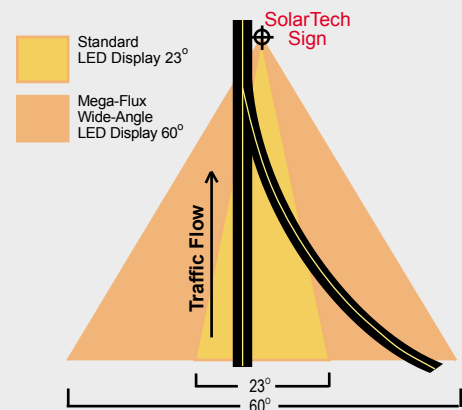
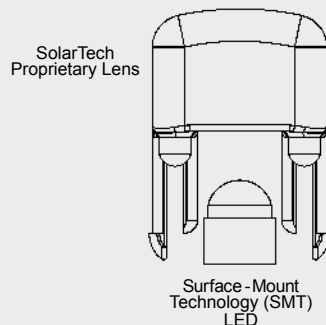



## DISPLAY

Panel Size .....	126 in. wide x 76 in. high (320 cm wide x 193 cm high)
Panel Construction .....	All aluminum, modular construction
Panel Face .....	3/16 in. Polycarbonate, non-glare
Matrix Size .....	27 x 48 pixels (standard)
Pixel Pitch .....	2.6 x 2.6 in. (6.6 x 6.6 cm)
Characters per Line .....	Up to Twelve (12)
Number of Lines .....	Up to Four (4)
Number of Fonts .....	Seven (7)
Character Height .....	13 to 52 in. (33 cm to 132 cm)
Graphics Capability .....	Full Matrix with Full Animation
Display Technology .....	LED (Amber, 592 nm)
Display Brightness .....	>10,000 cd/m2 (candela per sq. meter)
Viewing Angle .....	23° horizontal (minimum)
Display Life Expectancy .....	10 years typical
Lifting Mechanism .....	2,000 lb. capacity electro-hydraulic

## TRAILER

Length Overall .....	180 in. (457 cm)
Width Overall .....	92 in. (234 cm)
Width Across Fenders .....	92 in. (234 cm)
Height Traveling .....	103 in. (262 cm)
Height Operating .....	162 in. (412 cm)
Ground Clearance .....	13 in. (33 cm) min.
Weight .....	2,400 lbs. (1,089 kg) min. 2,960 lbs. (1,343 kg) max.
Coupler (Class III) .....	2-in. (5.1 cm) ball or 3-in. (7.6 cm) pintle ring
Axle/Suspension .....	Torq-Flex - independent

## ENERGY SOURCE

Operating Voltage .....	12 Volts DC (nominal)
Battery Type .....	6 Volt Heavy Duty, Deep Cycle (GC-2)
Number of Batteries .....	Four (4) Standard Lead Acid (Flooded)
Battery Bank Capacity .....	600 Amp Hours
Battery Status Indicator .....	Displays battery voltage, charging activity and low battery condition
Solar Array Construction .....	Top-mounted solar panels in aluminum frame
Solar Array Power Output ....	Standard 150W (nominal) 170W (peak)
Solar Charge Controller.....	Automatic, temperature compensated

## MEGA-TECH CONTROL CONSOLE

Console Circuitry .....	Ultra-low power solid state
Console Touchscreen .....	Waterproof, backlit, full-color GUI, intuitive icon-driven, multi-lingual
Programming Software .....	Proprietary, field upgradable
Message Capacity .....	Pre-programmed and user-programmed greater than 250 each
Time-Date Control .....	Real-time clock/calendar (365-day)
Message Display Time .....	User-selectable (0.1 to 99 seconds)
Display Update Time .....	Instantaneous
Non-Volatile Memory .....	Separate backup battery
Password Protection .....	User-selectable, multi-level
Operator Interface .....	Easy-to-use icons (no manual required)
Connectivity .....	Networkable (wired or wireless) and NTCIP compatible (Ethernet and RS-232)

## **OPTIONAL FEATURES AND UPGRADES**

### **Display Panel**

- MegaFlux Display - 60° Viewing Angle
- High-Definition Display - 30 x 56 Pixels 2.3 in. (5.8 cm) Pixel Pitch (Available in standard or Mega-Flux)

### **Brakes**

- Hydraulic Surge Brakes (5,000 lb. Capacity)
- Electric Brakes

### **Battery Upgrades**

- Eight (8) Lead-Acid (Flooded) (1200 AH Capacity)
- Twelve (12) Lead-Acid (Flooded) (1800 AH Capacity)
- Four (4) Gel-Cell Maintenance-Free (600 AH Capacity)
- Eight (8) Gel-Cell Maintenance-Free (1200 AH Capacity)
- Twelve (12) Gel-Cell Maintenance-Free (1800 AH Capacity)

### **Solar Array Upgrades**

- 225W (nominal) - 255W (peak)
- 300W (nominal) - 340W (peak)
- 375W (nominal) - 425W (peak)
- 450W (nominal) - 510W (peak)

### **Remote Control Options**

- Short-Range Wireless - 802.11 WiFi
- Cellular Wireless - GPRS (CDMA/GSM)
- Cellular Wireless - GPRS (CDMA/GSM) with GPS

### **Radar Options**

- MPH
- KPH

### **Other SolarTech Products**

#### **SILENT SENTINEL**

Trailer and Truck Mount Arrow Boards

#### **SILENT MESSENGER II**

Mid-Size Trailer and Vehicle Mount Message Boards

#### **SILENT MESSENGER III**

Small-Size Trailer and Vehicle Mount Message Boards

#### **SILENT ADVISOR**

Low and High Speed Application Radar Speed Trailers



Kilshanroe, Enfield,  
County. Meath, Ireland  
tel: 046-9541300 fax: 046-9541346  
email: [info@highwaymarkings.ie](mailto:info@highwaymarkings.ie)  
[www.highwaymarkings.ie](http://www.highwaymarkings.ie)